



# EXTENSIVE RANGE OF APPLICATION SOLUTIONS

## CONTENTS

Application	Products	Products	Page No.
<b>Infrastructure Development</b>	- Rock Breakers	Alicon & New Alicon Super+	4
	- Super Long Reach	Intelligence Series Rock Breaker	6
	- Rotating Crushers	Quick Coupler	7
	- Plate Compactor	Auger	8
	- Sorting Grapple / Rake	Super Long Reach	9
	- Drum Cutter	Clamshell Bucket	10
<b>Demolition / Crushing</b>	- Rock Breakers	Material Handler	11
	- Rotating Crushers	Orange Peel Grab	12
	- Sorting Grapple / Rake	Rotating Crusher	13
	- Drum Cutter	Sorting Grapple/Rake	14
	- Shear	Drum Cutter	15
<b>Mining</b>	- Mining Rock Breakers	Shear	16
	- Drum Cutter	Wood Grapple	17
	- Slurry Pump	Plate Compactor	17
<b>Urban Development</b>	- Rock Breakers	Mulcher	18
	- Super Long Reach	Hedge trimmer	19
	- Rotating Crushers	Slurry Pump	20
	- Sorting Grapple / Rake		
	- Orange Peel Grab		
	- Plate Compactor		
	- Clamshell Bucket		
	- Mulcher		
	- Hedge Trimmer		
	- Auger		
	- Shear		
- Slurry Pump			
<b>Inland Waterway Developments</b>	- Super Long Reach		
<b>Irrigation - Canal Excavation</b>	- Rock Breakers		
	- Super Long Reach		
	- Plate Compactor		
<b>Metal Recycling / Material Handling</b>	- Shear		
	- Orange Peel Grab		
	- Clamshell Bucket		
	- Sorting Grapple / Rake		
	- Material Handler		
<b>Forestry</b>	- Wood Grapple		
	- Auger		
<b>Tunnelling</b>	- Rock Breakers		
	- Drum Cutter		
<b>Others</b>	- Quick Coupler		

# TATA HITACHI ATTACHMENTS FOR ALL APPLICATIONS

An extensive range of customized attachments that meet the demands of specific industry applications. These include Urban Development, Inland Waterways, Irrigation, Demolition/ Crushing, Material Handling, Metal Recycling, Mining, Tunnelling and many more.





# ALICON & NEW ALICON SUPER+

## FEATURES

- New Alicon series lighter, stronger, and more powerful than ever.
- Anti-blank firing system provides higher durability.
- 2-stroke selector enables selection of stroke based on application.
- Bending design of the bracket makes the breaker more durable and less noisy.
- Wide range of product lines which fit into any kind of working condition.
- Choice of optional features: TPC system, internal relief valve, BPM adjust valve, provision for underwater works and Auto-Grease System.

## SPECIFICATIONS

### CONSTRUCTION SEGMENT

Breaker Model	Unit	B30	B60 Super	B70	B145 Super+
Excavator Weight Class <sup>1)</sup>	Ton	2-4	4-8	6-8	10-15
Operating Weight <sup>2)</sup>	kg	180	375	431	959
Oil Flow	Lpm	25-45	35-70	45-80	90-110
Operating Pressure	Bar	80-120	100-140	100-140	120-160
Impact Blow Rate	Bpm (High speed)	600-1100	350-800 (450-1000)	350-850 (450-1100)	350-550
Overall Length (w/STD.MTG.BKT)	mm	1334	1635	1805	2,263
Chisel Diameter	mm	53	75	78	105
Chisel Length	mm	570	780	806	975
<b>Tata Hitachi Suitable Excavator</b>	<b>Model</b>	<b>TMX20 Neo/ ZX23U/ZX33U</b>	<b>SHINRAI PRIME/ SHINRAI PRO</b>	<b>EX70 Prime / SHINRAI PRIME/ SHINRAI PRO</b>	<b>EX130 Super+/ ZX140H</b>

## CHOICE OF OPTIONS

Underwater Works	—	—	—	●
Auto-Greasing System Hole	—	●	●	●
TPC <sup>3)</sup> System Selector Type	—	●	●	●
ABF(Anti-Blank Firing) System	—	●	●	●
Auto-Greasing Unit	—	●	●	●
Central Grease Supply Unit	—	●	●	●
BPM Adjuster	—	—	—	●
Internal Relief Valve	—	—	—	—
TPC System Remote Control Type	—	—	—	—
Low-Noise Housing Bracket	●	●	●	●

## APPLICATION



### MINING & QUARRYING

- Primary Breaking
- Secondary Breaking



### METALLURGICAL INDUSTRY

- Slag Recycling
- Cleaning & Debricking



### DEMOLITION & RENOVATION

- Masonry Structures
- Concrete Structures
- Composite Steel
- Pavements –Asphalt, Concrete



### CONSTRUCTION

- Earthwork
- Trenching
- Ground excavation
- Tunneling
- Foundation work
- Building construction



# INTELLIGENCE SERIES ROCK BREAKER

## FEATURES

- Operates entirely on the latest Hydraulic Technology.
- Excellent power-to-weight ratio.
- High-impact & constant blow leads to increased productivity.
- Rotational type bushes increase life up to 50%.
- Auto-Lubrication system as a standard feature across medium & large range.
- VIDAT Tie Rods - Absorbs vibration and prevents premature failures.
- In-Built Hydraulic protection system.
- MyFleet - Live geo-tracking and breaker performance data.



MyFleet - Live Geo-Track-



Auto-Lubrication System

## SPECIFICATIONS

### CONSTRUCTION SEGMENT

### MINING SEGMENT

Breaker Model	Unit	BR777i	BR1655i	BR2577i	BR3288i	BR4099i	BR5011i	BR9033i
Excavator Weight Class	Ton	4.3-9.5	12 ~20	21-32	26-42	34-55	43-80	65-120
Operating Weight	Kg	390	1100	1670	2400	3380	4750	7400
Oil Flow	Lpm	40-120	90-130	140-200	160-250	250-350	280-380	360-460
Operating Pressure	Bar	90-140	135-145	135-145	150-160	150-160	160-170	170-180
Impact Blow Rate	Bpm	500-1700	500-920	450-750	370 ~ 630 (L)* 460 ~ 740 (S)*	400 ~ 560 (L)* 520 ~ 700 (S)*	370 ~ 530 (L)* 450 ~ 620 (S)*	300 ~ 520 (L)* 355 ~ 645 (S)*
Chisel Diameter	mm	80	115	135	142	166	190	215
Tata Hitachi Suitable Excavator	Model	SHINRAI PRIME/ SHINRAI PRO/ EX 70 Prime	EX 130/ ZAXIS 140H	EX 200LC, EX 210LC ZAXIS 220LC/EX 215LCQ ZAXIS 220LC-M	ZAXIS 370LCH, ZAXIS 400MTH	ZAXIS 470H	ZAXIS 650H	ZX870H EX1200V

\* L- Long Stroke and S- Short Stroke

## CHOICE OF OPTIONS

Auto Greasing	●
Anit-Blank Firing	●
Hydraulic Protection System	●
Low-Noise HD Housing	●
Under water Application	●
Tunnel Application	●

- 1) Standard weight of carrier.
- 2) Standard weight hydraulic breaker with adaptor and tool.

## APPLICATION



### MINING & QUARRYING

- Primary Breaking
- Secondary Breaking



### DEMOLITION & RENOVATION

- Masonry Structures
- Concrete Structures
- Composite Steel
- Pavements – Asphalt, Concrete



### METALLURGICAL INDUSTRY

- Slag Recycling
- Cleaning & Debricking



### CONSTRUCTION

- Earthwork
- Trenching
- Ground excavation
- Tunneling
- Foundation work
- Building construction

Standard 
  Option 
  N/A

# QUICK COUPLER

## TWIN LOCK POWER LATCH QUICK COUPLER

### FEATURES

- Quick Couplers facilitates rapid change of bucket and attachments increasing the equipment utilization and productivity.
- Fully Automatic hydraulic coupler with unique Automatic Blocking System (ABS) eliminating the need for a manually inserted safety pin.
- Strong, durable, high-tensile precision single piece cast steel frame.
- Twin-locking feature enables front and rear attachment pins mechanically locked, in the event of any hydraulic power loss.
- Attachments can only be removed in a safe, fully crowd-in position.
- Short Payback period of less than six months.



### SPECIFICATIONS

#### COUPLER RANGE / MACHINE TONNAGE

Description	Unit	Range 4	Range 6	Range 6FAB	Range 8	Range 9	Range 11	Range 13
Excavator Weight Class	Ton	11-15	19-23	19-23	30-39	40-49	65-70	100-120
Operating Weight	Kg	180	310	337	560	850	1350	2120
Front and Rear Pin diameter	mm	60 & 65	80 & 80	80 & 80	90 & 100	100 & 110	120 & 130	120 & 130
Attachments pick up range	mm	345-415	430-520	430-520	482-602	572-603	640-645	640-645
<b>Tata Hitachi Suitable Excavator</b>	<b>Model</b>	<b>EX130 Super+/ ZX140H</b>	<b>EX200LC Super+/ EX210LC Super+/ EX 215LCQ/ZX220LC</b>	<b>EX200LC Super+/ EX210LC Super+/ EX 215LCQ/ZX220LC</b>	<b>ZX370LCH</b>	<b>ZX470H</b>	<b>ZX650H</b>	<b>EX1200V</b>

### MECHANICAL QUICK COUPLER

### FEATURES

- Structural integrity & life is increased for main Attachment component.
- Simplified and Cost-effective system.
- Hardox steel for high durability.

### SPECIFICATIONS

Description	Unit	Range 3
Excavator Weight Class	ton	4-8
Operating Weight	kg	87
Front and Rear Pin diameter	mm	50&55
Attachments pick up range	mm	348-350
<b>Tata Hitachi Suitable Excavator Models</b>		<b>Shinrai Prime/ Shinrai Pro</b>





# AUGER

## FEATURES

- Manufactured from high grade materials & precision engineered products.
- Designed to withstand extreme working conditions.
- Unique Design of single piece drive shaft to prevent shaft dislodgement.
- Interchangeable wear parts & pilot extensions for improved flexibility and accuracy.
- Amplified torque & High efficiency due to planetary gearbox.
- Best in class warranty policy



## SPECIFICATIONS

Description	Unit	3000 Max	3500 Max	8000 Max	15000 Max	25000 Max	42000 Max
Torque Range	Nm	959-2877	1,205-3,614	2,717-8,152	5,024-15,071	16,503-24,755	24,612-42,387
Oil Pressure Range	Bar	80-240	80-240	80-240	80-240	160-240	180-310
Oil flow Range	Lpm	27-75	40-85	70-150	80-170	80-170	80-225
Unit Weight	Kg	71	73	116	173	269	442
Auger Diameter Range	mm	100-600	100-750	150-1.2	150-1.2	150-1.5	300-1.8
Auger Depth Range	M	1.4-3	1.4-3	2.4-6	3.7-7.5	4.1-9	4.9-11.5
Output Shaft Std.	mm	65	65	75	75	75	110
Suitable Machine Class	Ton	2-4	2.5-4.5	6-8	10-15	15-22	20-45

## APPLICATION



ELECTRICAL  
POLE



PLANTATION,  
FOUNDATION/ CASING  
INSTALLATION



SOLAR PANEL  
INSTALLATION



DEWATERING  
APPLICATION



LANDSCAPING,  
FENCING,  
BORING ETC.



# SUPER LONG REACH

## APPLICATIONS

- Desilting operations in ports, canals & lakes.
- Agriculture well rejuvenation.
- Inland waterways development.
- Urban construction work.
- Road construction & bridges.
- Miscellaneous applications such as salt pans & fly ash handling.
- Seawall construction & Dredging.



## SPECIFICATIONS

Excavator Operating Weight	Length		Max. Reach		Max. Depth		Max. Height		Boom Height		Approximate Bucket Capacity
	m	ft	m	ft	m	ft	m	ft	m	ft	
11-14 ton	12	40'	11.9	39'10"	7.9	25'11"	12.35	40'6"	2.3	7'6"	0.35
20-22 ton	14.5	47'5"	14.5	47'5"	11.05	36'2"	12.11	39'7"	2.3	7'5"	0.5
	15.5	50'8"	15.5	50'8"	11.62	38'1"	13.5	44'2"	2.5	8'2"	0.4
33-38 ton	18.5	60'	18.5	60'	13.9	54'7"	16.15	52'11"	3.15	10'4"	0.7
40-45 ton	21	69'	21	69'	13.95	45'9"	15.4	50'6"	3.7	12'1"	0.8
60-68 ton	23.5	77'	23.5	77'	17	55'9"	19.95	65'5"	3.95	12'11"	1.5
80-95 ton	23.5	77'	23.5	77'	17.35	56'11"	19.95	65'5"	4.25	13'11"	1.6
	25	82'	25	82'	18.65	61'2"	20.95	68'8"	4.35	14'3"	1.5
100-125 ton	25	82'	25	82'	17.6	57'8"	21	68'10"	5.35	17'6"	2
	27	88'	27	88'	20.4	66'11"	18.8	61'8"	5.35	17'6"	1.8

Note- Long reach length & bucket capacity will vary upon application, hence consult with relevant team before offering to customer.

## APPLICATION



DREDGING



EROSION CONTROL AND PREVENTION



MAINTENANCE & CLEANING OF RIVERS, LAKES, SHORELINES, PONDS, ETC



DRAINAGE / LAND RECLAMATION WORK IN CITIES

# CLAMSHELL BUCKET

## LIGHT WEIGHT APPLICATIONS FEATURES

- Pendulum-type clam shell bucket which helps ease of operation during materials loading & unloading.
- Less operation cycle compared to normal operation.
- Rotating option: Hydraulic rotating type.
- Dual Cylinder: Dual hydraulic cylinder for excellent digging force.
- Optimal bowl radius for highest fill factor.
- Choice of option: Tooth points.



## SPECIFICATIONS

Description	Unit	DMCB1000
Operating Weight	kg	1250
Capacity	m <sup>3</sup>	1
Recommended Carrier	Ton	18-25

## HEAVY DUTY APPLICATIONS

### SPECIFICATIONS

Hydraulic Clamshell Grabs - Pile Density upto 1.0 T/m<sup>3</sup>

Type and size	Excavator Operating Weight (Ton)**	Grab capacity	Dead weight	Max. lifting capacity
HiCG	Ton	m <sup>3</sup>	Kg	Ton
600	18-30	0.6	1040	3
700	18-30	0.7	1100	3
800	18-30	0.8	1125	3
1250	18-30	1.25	1295	3
1500	18-30	1.5	1380	5
1600	18-30	1.6	1400	5
1750	18-50	1.75	1465	5
2000	18-50	2	1665	5
3000	18-50	3	2065	7
3500	18-50	3.5	2465	7

# SPECIFICATIONS

Hydraulic Clamshell Grabs - Pile Density upto 2.0 T/m3.

Type and size	Excavator Operating Weight (Ton) (**)	Grab capacity	Dead weight	Max. lifting capacity
HiDG	Ton	m3	Kg	Ton
600.27	12-20	0.6	915	4.0
700/800.28-S	18-30	0.8	1290	6.0
1000.28-S	18-30	1	1470	6.0
1200.28-S	18-30	1.2	1520	6.0
1600.28-S	18-50	1.6	1715	6.0
2000.28-S	18-50	2	1990	6.0
3000.28-S	18-50	3	2040	-

Remarks: \*\*\* As per Excavator Arm width & Arm pin diameter. \*\* Excavator Operating weight will change depending upon material application

# MATERIAL HANDLER

## FEATURES

- Customized design for superior lifting capacity & better stability.
- Reinforced structure to meet tough operating conditions.
- Boosts production and widens working ranges with long term cost saving.



## SPECIFICATIONS

Excavator Model	Reach (meter)
ZX370LCH	12m
Zx470H	14m
Zx650H	16m

## APPLICATION



**HIGH VOLUME BULK MATERIAL HANDLING**



**IDEAL FOR LOADING & UNLOADING BULK CARGO AT DOCKS**



**REPLACES CABLE OPERATED MATERIAL HANDLING MACHINES.**



**MATERIAL HANDLING**

- Industrial wastes, grains, sands, etc.



**LOADING AND UNLOADING**

- Coal, iron ore, gravel, clinker from railway wagon and barge.



# ORANGE PEEL GRAB

## FEATURES

- Loading/unloading metal scrap, wastes and garbage.
- Pendulum type.
- Rotating options: Hydraulic rotating type, free rotating type or fixed type.
- Number of tines: 4/5/6.
- Tines options: Close type, semi-close type, open type.



## LIGHT WEIGHT APPLICATIONS

### SPECIFICATIONS

Description	Unit	DMSG800
Operating Weight	kg	1,200
Capacity	m3	0.7
Recommended Carrier	ton	18~25
Standard Tines No.	ea	5

## HEAVY DUTY APPLICATIONS

### SPECIFICATIONS

Type and size	Excavator Operating Weight (Ton)(**)	Grab capacity	Dead weight in kg by Tines design			Number of Tines (**)	Max. lifting capacity
			Open	Semi-open	Closed		
HiOG	Ton	m3	Open	Semi-open	Closed	No.	Ton
600.25	12-22	0.6	1245	1310	1395	5	3.5
800.25	12-22	0.8	1270	1330	1440	5	3.5
2000.28-S	20-40	2	2210	2380	2700	5	6

Remarks: \* 5 no. Tines are standard. \*\* No. of tines can be changed depending upon the material size & shape.

\*\*\* As per Excavator Arm width & Arm pin diameter

## APPLICATION



**SORTING**



**WASTE HANDLING**



**CLEANING SITES**



**LOADING**



**METAL RECYCLING**

# ROTATING CRUSHER

## FEATURES

- 360° workable direction.
- Workable on narrow building spaces or noise-regulated environment.
- Speed-up valve accelerates work speed. (Optional)
- Moving arm tooth replaceable as standard.
- Welding-tooth type and bolting-tooth type available.

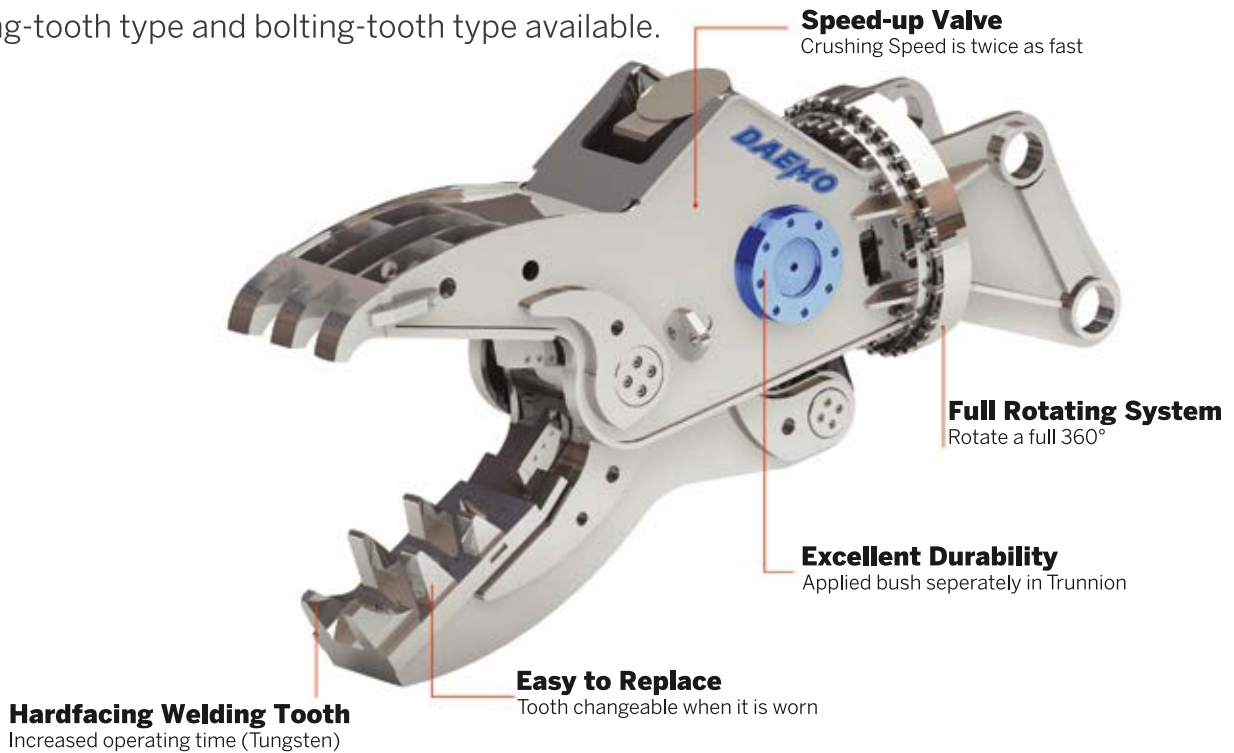

## SPECIFICATIONS

Description	Unit	DMC230R	DMC230RB	DMC330R	DMC330RB
Operating Weight	kg	2,250	2,300	3,050	3,100
Maximum Opening Width	mm	780	780	890	890
Overall Length	mm	2,500	2,480	2,660	2,685
Crushing Force (End)	ton	57	57	73	73
Operating Pressure	Bar	320	320	320	320
Oil Flow Rate	Lpm	200~250	200~250	250~300	250~300
Excavator Class	Ton	20~28	20~28	27~38	27~38

## APPLICATION



### STEEL STRUCTURES

- Cutting Steel Profiles
- Cutting Steel Girders/Beams
- Cutting Reinforcement



### REINFORCED CONCRETE

- Primary Demolition
- Secondary Demolition



### NON-REINFORCED CONCRETE

- Primary Demolition
- Wall Elements
- Secondary Demolition



### LIGHT DEMOLITION

- Light Structure
- Masonry
- Beams
- Inside Renovation

# SORTING GRAPPLE/RAKE

## FEATURES

- Link type/ Pendulum type mounting bracket depending upon site requirement.
- Rotation option type: fixed or hydraulic.
- Tooth replacement version.

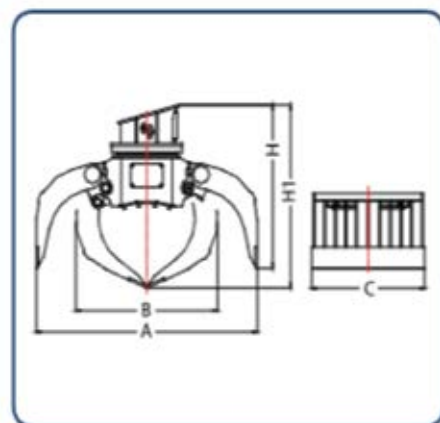

## SPECIFICATIONS

Description	Unit	DMR600	DMR800	DMR1000
Operating Weight	kg	970	1300	2200
Capacity	m <sup>3</sup>	0.36	0.6	0.93
Max Clamping Force	ton	3.7	5	7.4
A	mm	1790	2180	2445
B	mm	1210	1356	1485
C	mm	800	1000	1100
H	mm	1216	1437	1595
H1	mm	1379	1682	1900
Recommended Carrier	Ton	14~18	18~25	25~38

## APPLICATION



SORTING



WASTE HANDLING



CLEANING SITES



LOADING



# DRUM CUTTERS

## FEATURES

### LET'S CUT TO THE CHASE

Experience bigger benefits with the KDC-Series

- INCREASED PROFITABILITY**
  - Robust construction and low-maintenance operation
  - Precision profiling and cutting performance in hard soil and rock
  - Easy re-utilisation of cut material
- GREATER EFFICIENCY**
  - High pick force
  - Extremely high cutting-head torque
  - Maximum cutting force thanks to reduction gear unit
- MAXIMUM FLEXIBILITY**
  - Modular construction
  - Large selection of drum/pick options
  - Fast and easy exchange of wear parts

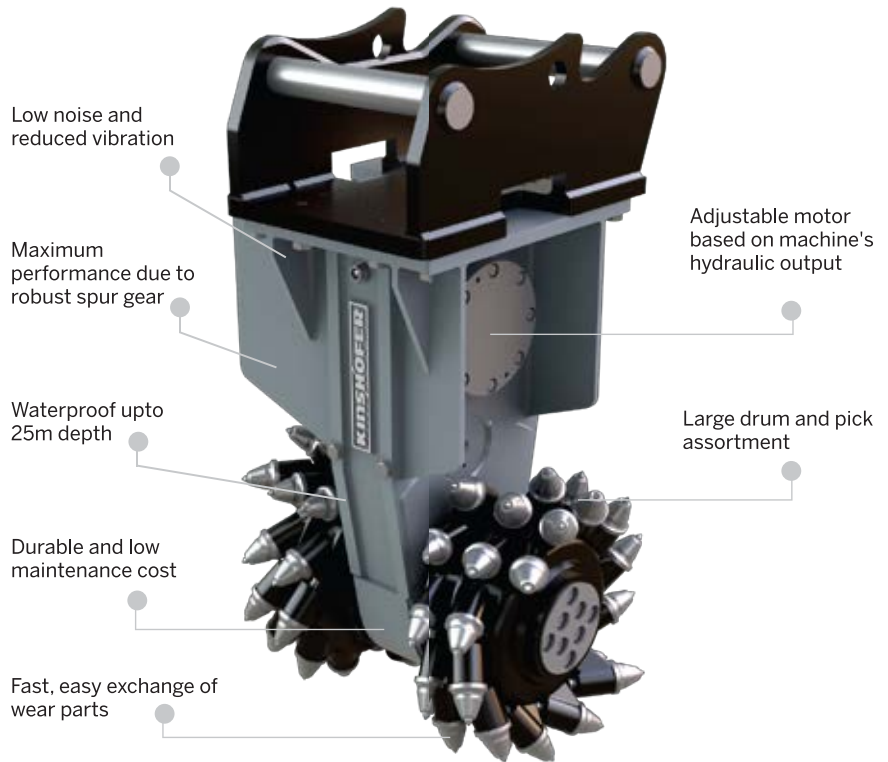

### CUTTING TECHNIQUE

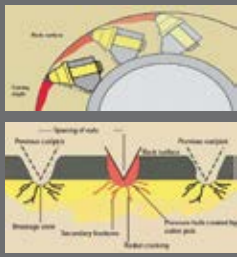

More than the performance of the cutter (kW), it is the pick force and cutting head torque which creates the optimal cutting operation.

The optimum arrangement of the picks guarantees a high loosening rate of the rock and a low overall wear rate – as a smoother cutting action reduces vibration on the excavator.

### Optional 360° degree rotation



Parameters		KDC04	KDC06	KDC08	KDC15	KDC20	KDC30	KDC35	KDC45	KDC60
Excavator Size	Ton	2-4t	2-4t	2-8t	8-15t	12-20t	18-30t	25-35t	25-45t	40-60t
Hydraulic Power	kw	18	18	22	30	45	60	90	120	150
Operating Weight	kg	250	250	250	420	850	1350	1400	2,550	2800
Working Pressure	bar	215 / 180			225 - 180	200 / 180	240 / 200	210 / 180	205 / 180	225 / 190
oil flow	lpm	48	50	60	90-115	100-170	140-210	240-340	300-500	360-600
Drum Speed	rpm	80 – 130			80 – 120	70 – 105	60 – 90	60 – 80	50 – 80	50 – 75
Cutting Speed	mps	1.6 – 2.0			1.6 -2.4	2.2 - 2.6	2.0 – 2.4	1.9 – 2.3	1.9 – 2.3	1.9 – 2.3
Cutter Torque	nm	2330	2330	4750	7880	9990	13650	24150	36200	43600
Pick force	kN	16 – 26.6			23 – 40	32 – 36	44.5	39.3	78 - 95	115
Number of picks	No.	44	44	44	48	56	56	56	64	80
Drum Diameter	mm	350	350	350	405	550	615	615	760	760
Cutting Width	mm	500	500	500	630	750	900	900	1,200	1,400
Height	mm	615	615	615	740	965	1095	1095	1,345	1345
Max Cutting Force	KN	13	16	29	40	36	44	79	95	114

## APPLICATION



MINING



INFRASTRUCTURE DEVELOPMENT



DEMOLITION & CRUSHING



TUNNEL

# SHEAR

## FEATURES

- 360° workable direction.
- H-beam and I-beam can be cut in a single cut.
- Easier cutter replacement.
- Speed-up valve accelerates work speed.
- Speed-up valve as standard for DMS400, DMS550X, DMS700.



## SPECIFICATIONS

Description		Unit	None Guide Block Type			Guide Block Type			
			DMS250	DMS300	DMS330	DMS360	DMS400	DMS550X	DMS700
Operating Weight		Kg	2,200	2,920	2,790	3,450	5,300	6,800	7,900
Max. Opening Width		mm	668	570	806	456	710	802	896
Overall Length		mm	2,353	2,410	2,588	2,690	4,625	5,050	5,480
Cutting Force (Max)		Ton	259	370	347	495	1,150	1,500	1,750
Operating Pressure		Bar	320	320	320	320	340	340	340
Oil Flow Rate		Lpm	200~250	250~300	250~300	290~320	200~320	250~320	320~
Excavator Class		Ton	22~27	27~33	27~33	33~45	25~ (2nd) 41~ (3rd)	36~ (2nd) 50~ (3rd)	42~ (2nd) 73~ (3rd)
Cutting Capability	H-Beam	mm	150×150	200×200	200×200	300×300	350×350	380×380	450×450
	I-Beam		200×125	300×150	300×150	350×150	400×175	600×190	600×190
	Solid Round		40	50	50	60	70	80	90
	Channel Plate		250×90×13	380×100×16	380×100×16	425×100×10	425×100×10	425×100×10	425×100×10
	Angle Plate		100×100×10	150×150×15	150×150×15	200×200×20	200×200×25	250×250×25	250×250×30

## APPLICATION



METAL  
RECYCLING



STEEL  
MILLS



INDUSTRIAL  
DEMOLITION



SHIP  
DEMOLITION

# WOOD GRAPPLE

## FEATURES

- Link type/ Pendulum type mounting bracket depending upon site requirement.
- Rotating type.
- Loading/unloading timbers, logs and pipes.
- Wide jaws suitable for various work requirement.



## SPECIFICATIONS

Model	Excavator Operating Weight (Ton) (**)	Area (tip to tip) (m <sup>2</sup> )	Tongs Width (mm)
HHG.32	18-34	1.00-1.75	800/640
HHG.33	30-60	1.25-2.50	800/640
HHG.34-K	30-60	2.50-4.00	800

Remarks: \*\* Excavator Operating weight will change depending upon material application

## APPLICATION



WOOD SORTING



WOOD HANDLING



WOOD LOADING/UNLOADING

# PLATE COMPACTOR

## FEATURES

- High compaction efficiency for ground, trench and slope.
- Requires only Breaker piping Kit.
- Control block system for easy & safe setting.
- Robust design with bending structure & hub type damper.



## SPECIFICATIONS

Description	Unit	DMV50	DMV140	DMV230	DMV300	
Impulse Force	Ton	2.3	3.7	7.5	11	
Weight	Kg	342	624	850	1282	
Compact Area	Width	mm	450	650	750	900
	Length	mm	700	750	1000	1200
Oil Flow Required	lpm	30-55	90-110	130-170	180-250	
Max Cycle Per Minute	rpm	2500	2500	2200	2200	
Operating Pressure	Bar	100~140	120~160	130~180	140~180	
Excavator Class	Ton	2-7	8~15	15~22	25~47	

## APPLICATION



ROAD CONSTRUCTION



SEWER & TRENCH CONSTRUCTION



SLOPE COMPACTION



EXTENSION FOR COMPACTION NARROW TRENCH



# MULCHER

## FEATURES

**RELIABLE & VERSATILE, WHATEVER THE JOB** Suitable for excavators & backhoe loader. Mulchers are designed and manufactured to handle the toughest clearance applications with precise hedge trimming.

### HEAVY DUTY CONSTRUCTION

- Solid steel structure
- Low profile design for good visibility
- Removable side plates for easy belt access
- Drainage holes for use in bad weather

### HINGED DOOR

- Adjustable for optimised performance
- Easy access for maintenance checks
- Heavy duty hinges & dual locking pins

### REMOVEABLE PUSH BAR & PRESSURE GAUGE

Easily convert from backhoe loader to excavator operation - remove the push bar & pressure gauge to help save on weight & bulkiness when attached to excavators.

### HEAVY DUTY BEARINGS & TRIPLE BELT SYSTEM

- Large bearings for smooth running & reliability
- Shrouded external greasing points
- Easy access triple belt system

### HEAVY DUTY DRUM - EASILY SWAPPED ON-SITE

- Drum change on-site with ease for maximum versatility
- Drums balanced to grade G16 and run 12mm thick sidewalls

### REPLACEABLE SKID PLATES

- Easily removed & replaced
- Also aids drum storage

### OPTIMISED CUTTING TEETH

- Designed for optimal strike rate & timing to prevent drum stall & clogging



#### FIXED TUNGSTEN TOOTH DRUM

- The toughest and most versatile option.
- Suitable for solid timber up to 250mm thick, lighter material like hedges and tree branches.



#### SWINGING HAMMER TOOTH DRUM

- Offers a cleaner cutting performance on soft materials.
- Ideal for lighter work where clean cutting of soft vegetation is required like reshaping dense hedgerows or processing hedge and branch trimmings into mulch.
- Capable of mulching smaller trees down to ground.

## SPECIFICATIONS

### VM1000

Standard Gear Motor  
 Oil Pressure Range: 160 - 180 BAR  
 Optimum Oil Pressure: 180 BAR  
 Oil Flow Range: 60 - 70 LPM  
 Optimum Oil Flow: 70 LPM

### SUITABLE FOR EXCAVATORS & BACKHOE LOADER

5T to 10T

### CUTTING

Drum Speed: up to 2400rpm  
 (parent machine dependant)  
 Cutting drum width: 1000mm  
 Processes trees up to 120 mm diameter

### DIMENSIONS

694mm x 1260mm x 802mm (h x w x d)

### WEIGHT

400 kg

### VM1500

Standard Piston Motor  
 Oil Pressure Range: 220- 240 BAR  
 Optimum Oil Pressure: 240 BAR  
 Oil Flow Range: 85 - 95 LPM  
 Optimum Oil Flow: 95 LPM

### SUITABLE FOR EXCAVATORS

10T to 15T

### CUTTING

Drum Speed: up to 2400rpm  
 (parent machine dependant)  
 Cutting drum width: 1500mm  
 Processes trees up to 250 mm diameter

### DIMENSIONS

865mm x 1830mm x 1002mm (h x w x d)

### WEIGHT

800 kg



## APPLICATION



URBAN  
DEVELOPMENT



MULCHING

# HEDGE TRIMMER

## FEATURES

### Hedge Trimmer for Excavator and Backhoe loader

Hedge Trimmer is the perfect addition for excavators (2.5-8T) and Backhoe loaders, and offers a variety of motor sizes to suit your application. Attaching to a base machine provides extra-long cutting reach, gaining taller trees and deeper hedges. The Hedge Trimmer is also ideal for cutting long grass and bushes.

Attaching the optional tooth extension bar provides a full 2.5m cutting length. This makes trimming more precise, efficient and will provide yet another way to expand the versatility of existing machines.

A neat and accurate cut, every time.



#### FEATURES

- 1.5m cutting length
- Optional 1m cutting extension bar
- Cuts up to 40mm diameter
- Replace individual cutting teeth as required

## SPECIFICATIONS

### HEDGE TRIMMER - T150

50cc Motor Variant	
Suited to	: Excavators (2.5T - 4.5T)
Oil Pressure Range	: 28-220 Bar
Oil Flow Range	: 8-65 lpm
80cc Motor Variant	
Suited to	: Excavators (4.5T - 8T)
Oil Pressure Range	: 28-220 Bar
Oil Flow Range	: 8-66 lpm
100cc Motor Variant	
Suited to	: Excavators (8T) & Backhoe loader
Oil Pressure Range	: 28-220 Bar
Oil Flow Range	: 8-71 lpm
Max. Back Pressure	: 20 Bar
Hose Port Diameter	: 1/2" BSP
Cutting Length	: 1500 mm
Max. Cutting Diameter	: 40 mm
Dimensions	: 203 h x 1537 w x 270 d (mm)
Weight	: 69 kg

\* Weight will vary subject to mounting type & extension

### EXTENSION

Cutting Length	: 1 m
Combined Cutting Length	: 2.5 m
Max. Cutting Diameter	: 40 mm
Dimensions (mm)	: 118 h x 1192 w x 225 d
Weight	: 69 kg

### OFFSET MOUNT

Max. Offset Distance	: 1.3 m
Cutting Angle	: Horizontal thru Vertical
Operating Voltage	: 12V
Dimensions (mm)	: 420 h x 245 w x 1510 l
Weight	: 56 kg

### SUITABLE TO TRIM

- Grass
- Bushes
- Protruding Branches



## APPLICATION



URBAN DEVELOPMENT



BUSH TRIMMING

# SLURRY PUMP

## FEATURES

### Hydraulic Submersible Slurry Pump

- Construction Site Dewatering Activities
- River water and dam desilting
- Power plant ash removal and cleaning
- Lagoon dredging and silt removal
- Harbour and dry-dock cleaning
- Sewage and waste transfer
- Minerals processing - separation, purification, concentration
- Open pit mine dewatering
- Mine tailings recovery and reprocessing
- Steel slag transport
- Rolling mill scale and metal cutting swarf transport

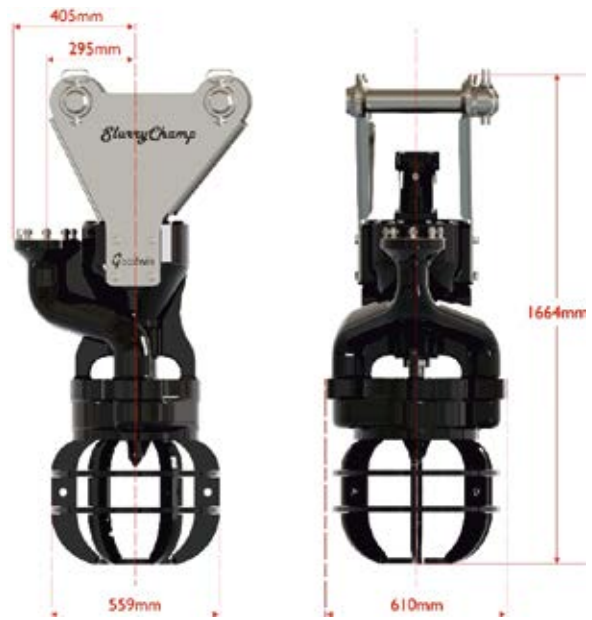

## SPECIFICATIONS

Suitable Excavator Range	10 Ton - 30 Ton	
Oil flow rate required for 1500 rpm*	93 lpm	
Oil Pressure required for pumping slurry up to 2.8 kg/l sg **	275 bar	
Maximum Pumped Slurry Specific Gravity (sg)	2.8 kg/l	
Maximum Pumped Slurry Solids Content	65 % by weight	
Maximum Pumped Particle Size	32 mm dia	
Recommended pH Range	4-10	
Weight of Pump with Quick Hitch Frame	510 kg	
Pump Outlet Diameter	100 mm	
Maximum Flow at Minimum Head	230 m <sup>3</sup> /h	
Maximum Head at Minimum Flow	37 m	
Maximum Submergence Depth ***	28 m	
Flow & Head Data given above is for optimum operating speed	1500 rpm	
Output Delivery Pipe diameter	100 mm	125 mm
<b>Illustrative Pumping Parameters @1500 rpm</b>		
Pumping Lift	10 m	10 m
Pumping Distance	300 m	500 m
Minimum Slurry Flow Rate to avoid Pipeline Blockage	60 m <sup>3</sup> /h	80 m <sup>3</sup> /h

## APPLICATION



**CONSTRUCTION  
SITE DEWATERING**



**OPEN PIT MINE  
DEWATERING**



**STEEL SLAG  
TRANSPORT**

# OUR NETWORK

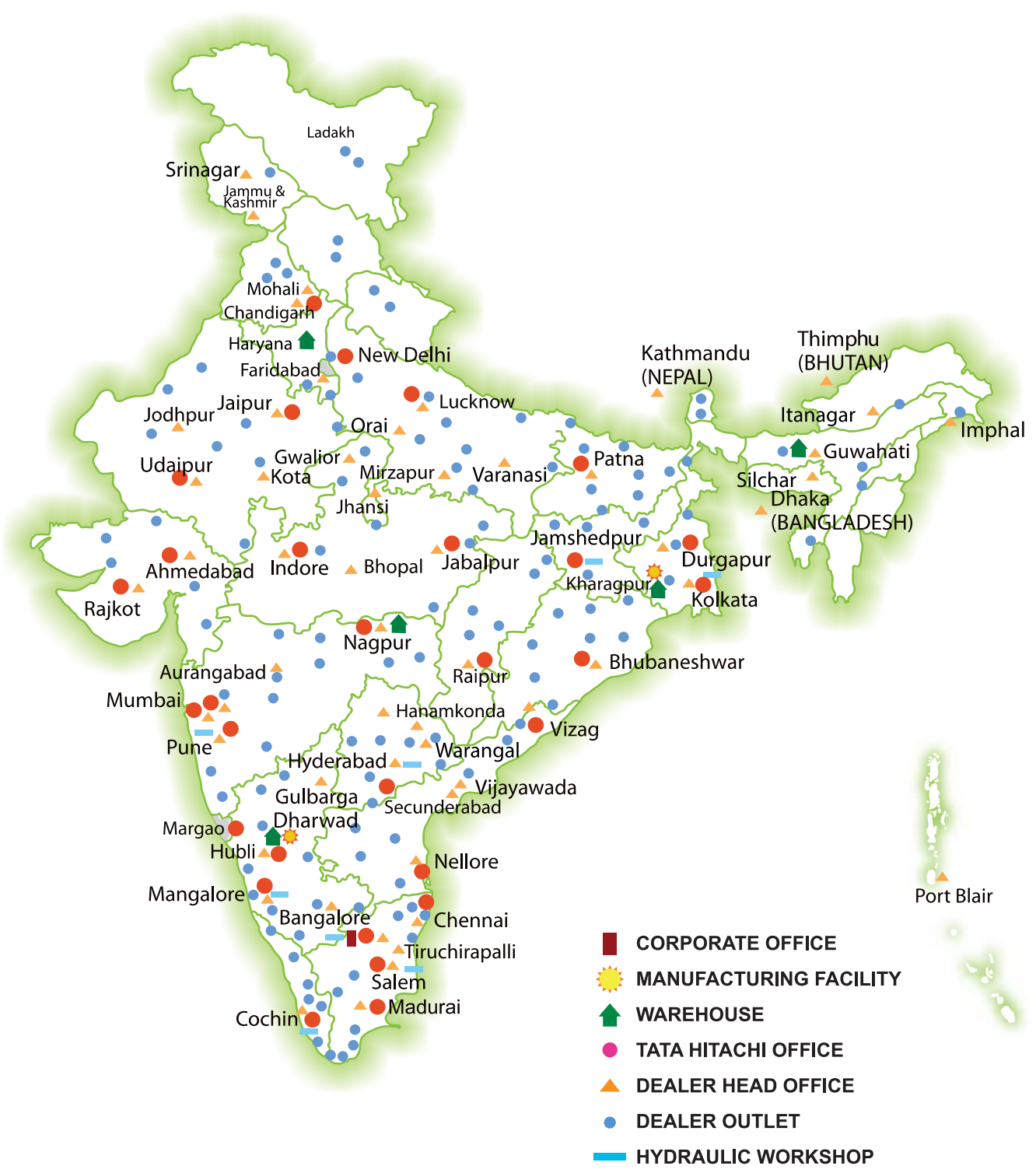

## Tata Hitachi Construction Machinery Company Private Limited

Registered Office: Jubilee Building, 45 Museum Road, Bangalore, India 560025  
 Telephone: +91 80 66953301 / 02 / 03 / 04 / 05 | Email: info@tatahitachi.co.in

[www.tatahitachi.co.in](http://www.tatahitachi.co.in)
Toll Free Number: 1800 121 6633

These specifications are subject to change without prior notice. The machine depicted may vary from the actual machine. Please contact our nearest office for latest specifications. Accessories shown here are not part of the standard equipment. Performance of the machine may vary with site and operating conditions encountered.

Authorised Dealer